

ZONE	REV	DESCRIPTION	DATE	APPROVED

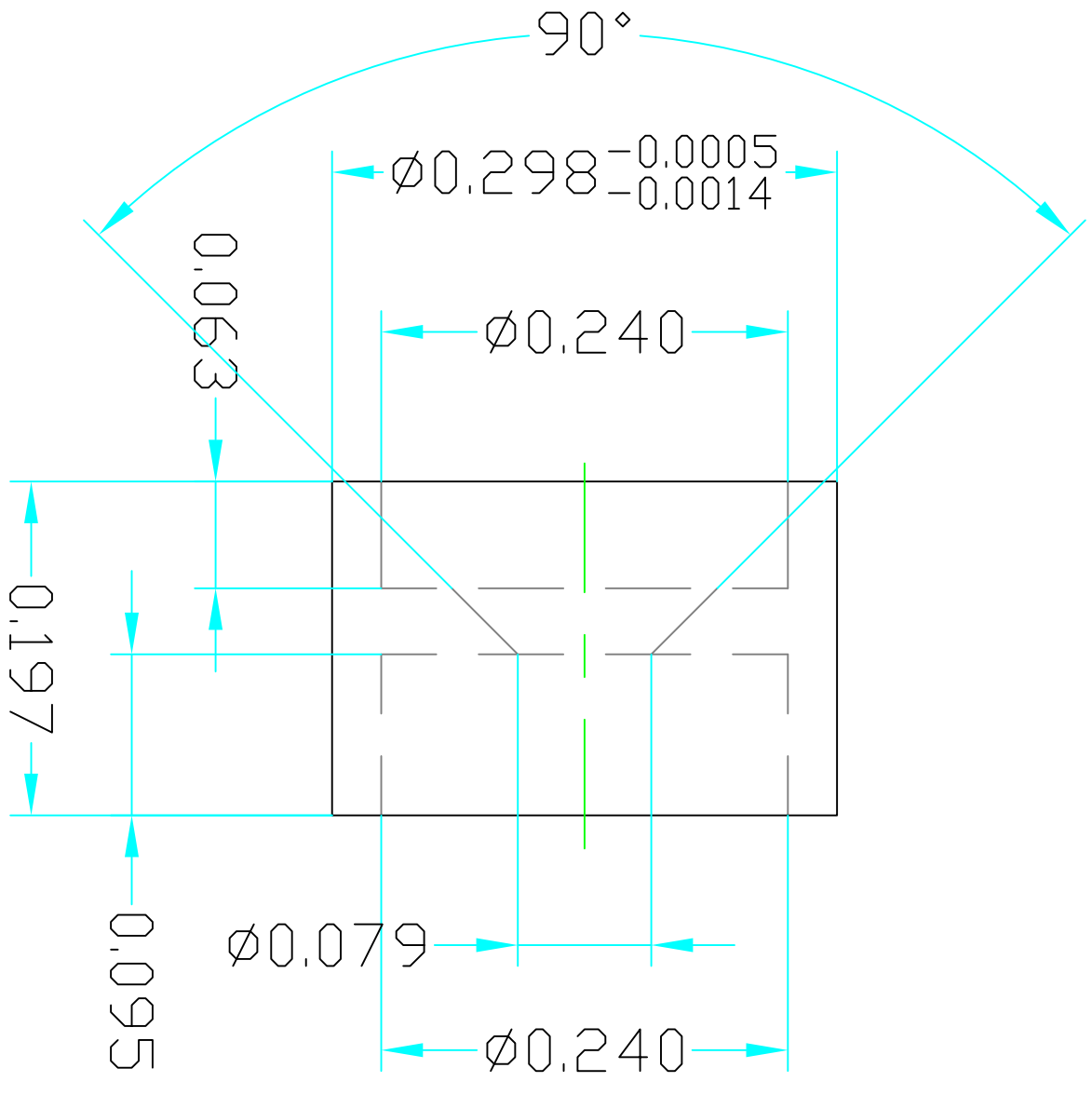
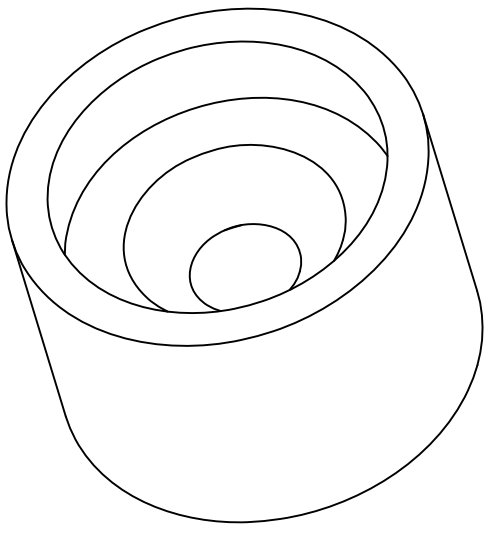

PART#	QTY.	UM.	PART NAME	MATERIAL	REF. SHEET/DWG
500.10.01.00	1	EA	HOLDER	BRASS	

PARTS LIST				PERMISSIBLE VARIATION IN INCH DIMENSIONS WITHOUT TOLERANCES			
UNLESS OTHERWISE SPECIFIED							
FABRICATION TOLERANCES				MACHINING TOLERANCES			
1. DIMENSIONS ARE IN INCHES.	2. MACHINE SURFACES TO BE FLAT, SQUARE, PARALLEL & CONCENTRIC BELOW 12	3. XX	XXX	12 TO 60	±0.10	DECIMAL PLACES X & XX	XXX
4. BREAK ALL SHARP CORNERS 01 x 45° CHAMFER.	5. FILLETS SHOWN SHARP = .04 RAD.	6. TAPPED HOLES UNF/TF CLASS 2B THREAD, MIN DEPTH 1.5 x DIA	7. CHAMFERED & REAMED HOLES 1/16 x 45°	60 TO 180	±0.13	BELOW 18	±0.015
8. CENTERS PERMISSIBLE	9. ALL DIMENSIONS TO CENTER UNLESS OTHERWISE SPECIFIED	10. ALL VELDING TO CONFORM TO LATEST AWS STANDARDS	11. TOLERANCES ARE NOT ACCUMULATIVE	18 TO 48	±0.20	18 TO 48	±0.030
12. SURFACE TEXTURE: Ra 3.2	13. SURFACE TEXTURE: Ra 1.6	14. SURFACE TEXTURE: Ra 0.8	15. SURFACE TEXTURE: Ra 0.4	OVER 180	±0.30	OVER 48	±0.045
16. SURFACE TEXTURE: Ra 0.2	17. SURFACE TEXTURE: Ra 0.1	18. SURFACE TEXTURE: Ra 0.05	19. SURFACE TEXTURE: Ra 0.025				

REV	DATE	BY	CHKD	APP'D	DESCRIPTION

REV	DATE	BY	CHKD	APP'D	DESCRIPTION

REV	DATE	BY	CHKD	APP'D	DESCRIPTION

REV	DATE	BY	CHKD	APP'D	DESCRIPTION

NOTES:
1. DO NOT SANDBLAST

